

PTO 01/300
PTO 01/400
PTO 01/500
PTO 01/600

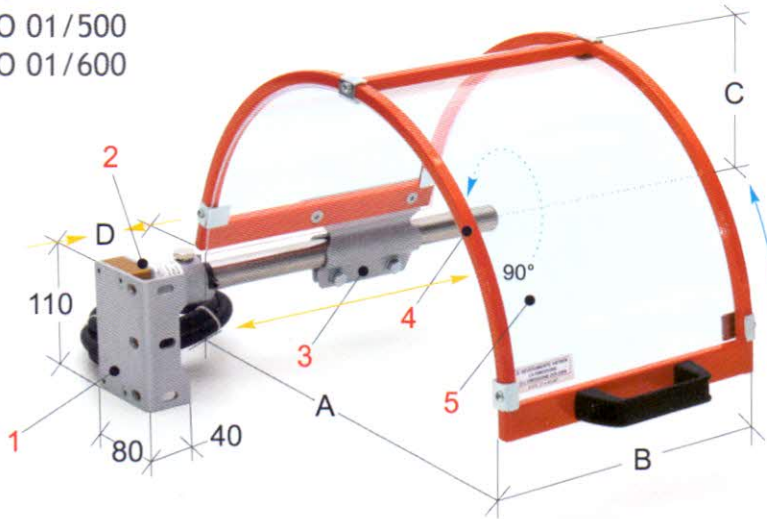

Classic safety guard equipped with steel-framed shield. The only one positionable until the machine head.

Protects the operator from direct contact with the upper part of the lathe chuck and from lubricant-coolant projection. Frontally and laterally attachable at the base. Equipped with semicircular shield, adjustable until the machine head. Complete with safety microswitch.

- 1 Frontal and lateral anchorage stirrup
- 2 Safety microswitch main box - 90° rotation - n.2 NC contacts
- 3 Shield connection clamp with support arm - in pressed steel
- 4 Shield structure in tubular steel
- 5 Thermo-shaped shield - in shockproof and oil-resistant plastic material

Code	A	B	C	D	Kg.
PTO 01/300	300	200	180	0-215	3,6
PTO 01/400	400	235	230	0-150	4,1
PTO 01/500	500	235	280	0-150	4,4
PTO 01/600	600	235	330	0-150	4,7

PTO 02/300
PTO 02/400

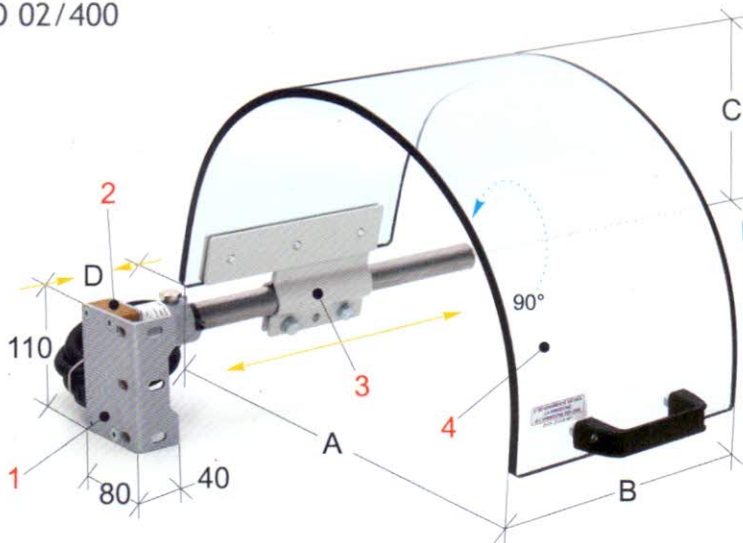

The shield shape makes it ideal to be positioned until the machine head. Equipped with monolithic shield in plastic material.

Protects the operator from direct contact with the upper part of the lathe chuck and from lubricant-coolant projection. Frontally and laterally attachable at the base. Equipped with semicircular monolithic shield, adjustable until the machine head. Complete with safety microswitch.

- 1 Frontal and lateral anchorage stirrup
- 2 Safety microswitch main box - 90° rotation - n.2 NC contacts
- 3 Adjustable shield connection clamp with support arm - in pressed steel
- 4 Monolithic shield - in thick plastic shockproof and oil-resistant material

Code	A	B	C	D	Kg.
PTO 02/300	300	200	200	0-200	3,0
PTO 02/400	400	220	250	0-190	4,9